



Parkline N 5001

Above ground system with sliding principle
and with minimal ground area requirements

Area of application

residential buildings, hotels and office buildings

The Parkline N 5001 serves as independent parking on 2 levels, above ground. The entrance level has sliding platforms and one empty space. The top platforms move only vertically.

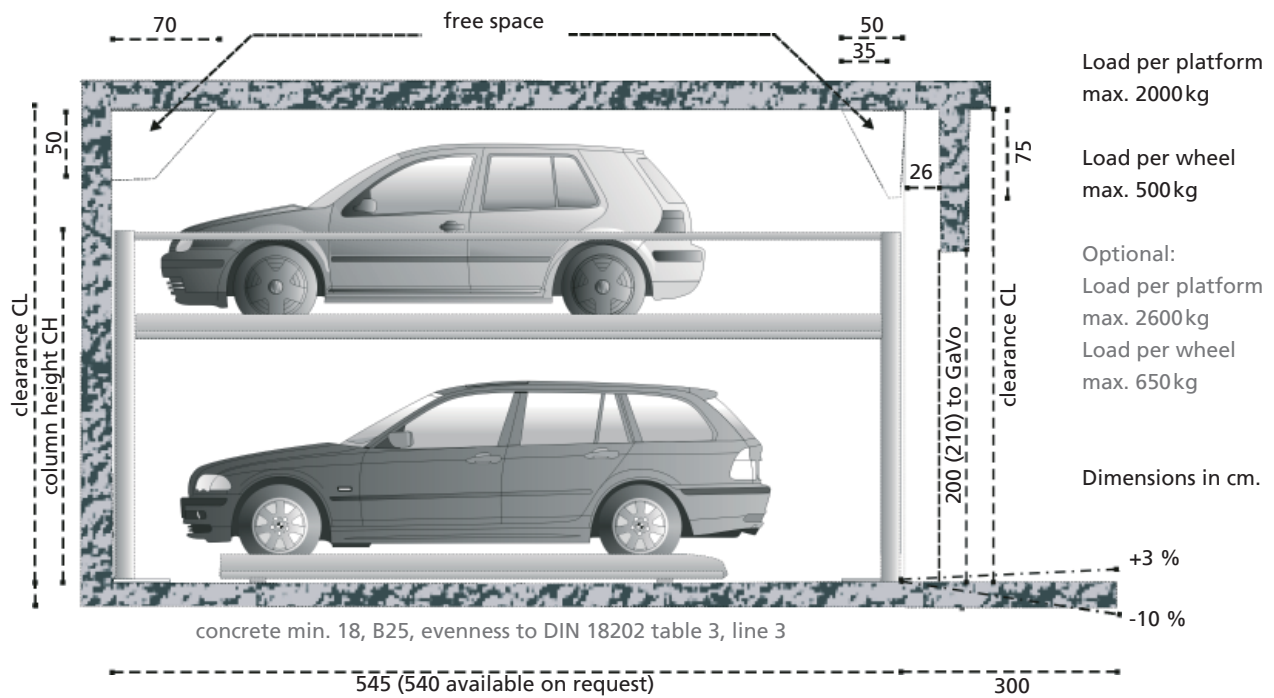

System versions

column height CH	215	235	235
clearance CL	325	345	405
car height below	150	170	170
car-height above	150	150	210

■ standard

Vehicle data

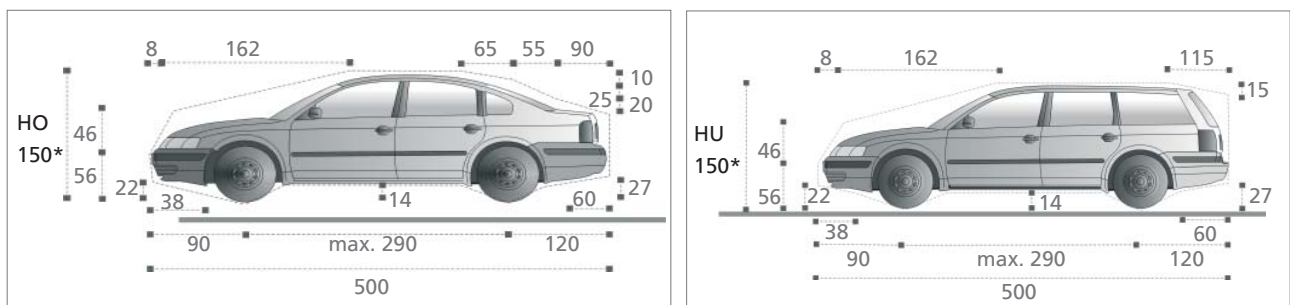

standard: max. car width 190cm, max. load per platform 2000kg, max. load per wheel 500kg

Optional vehicle data

Vehicle length: up to 520cm, load per platform max. 2600kg, load per wheel max. 650kg

Solid design with four columns

Width dimensions, fig. 3 segments for 5 parking spaces

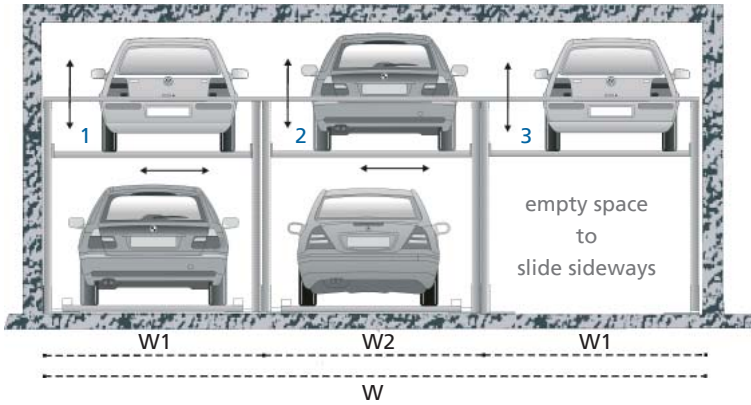

The smallest sensible unit are 2 segments for 3 cars. The system can be extended in any order. But we recommend to position not more than 10 segments for 19 cars side by side with one common hydraulic unit.

platform-width	raster outer B1	raster inner B2	total dimension W by x segments			
			3	4	5	6
230	255	250	760	1010	1260	1510
240	265	260	790	1050	1310	1570
250	275	270	820	1090	1360	1630
260	285	280	850	1130	1410	1690
270	295	290	880	1170	1460	1750

Installation layout gates

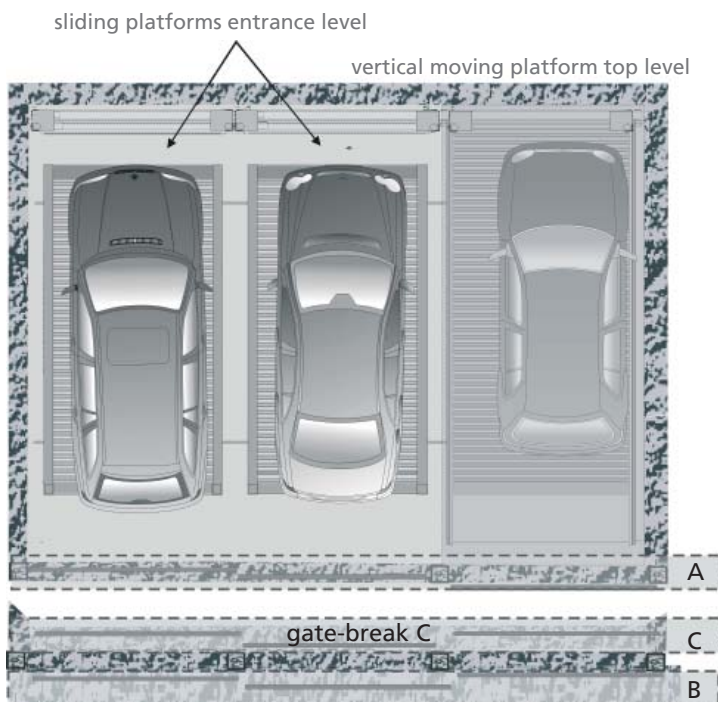

Standard: Without gates, with dead man's control
 Fixation of gate max. 210cm clearance
 (gates not necessary, gates deliverable as option with automatic control)

Layout A

Sliding doors between pillars, columns supplied by the employer min. every 2 segment, otherwise assembly of the gates in front of the column.

Layout B

Sliding doors in front of pillars.

Layout C

Sliding doors behind pillars of gate-break: The employer must consider the system length of 545cm behind the door step of his sliding door.

Features in the scope of supply



Control element

Touch Screen with key-switch, emergency stop in dead man's control with brief operating instructions and wiring to the hydraulic unit.

Hydraulic unit

Hydraulic unit "Silencio" with tubing and wiring to the installation. The oil-submerged motor "Silencio" is extremely quiet and smooth running. The motor-pump assembly is sound absorbent.

We recommend, according to the access times, to use max. 10 segments with one hydraulic unit.



Location

According to the local requirements – preferable placed near the rear columns/cylinders

Dimensions LxWxH (length x width x height)

hydraulic unit:
approx. 60 cm x 22 cm x 40 cm

switch cabinet:
approx. 60 cm x 22 cm x 80 cm

Scope of supply

Installation with sliding platforms and one empty space on the entrance level and on top with vertical moving platforms. Completely with hydraulic driving elements and electrical control elements.

Mono-hub cylinder to drive the horizontal movable platforms with looped-around suspension elements, sliding platforms with electrical drive.

Width of parking spaces

Width of space 230cm and clearance 345cm as standard.

Safety devices

- entering wedges for easy drive-in and parking
- mechanical locking device prevents lowering by pipe breakage
- fixation of the installation and the hydraulic unit with HD-anchors, wiring and impact dowels

Protection against corrosion

Corrosion protection "Classic" of driving plates by continuous line-galvanizing to DIN EN 10142/10143.

Corrosion protection "Classic Plus" of driving plates by line-galvanizing and powder coating to DIN EN 10142/10143 and surface coating on top (depending on the market specific needs zinc and powder coated sheet metal included in the scope of supply).



Driving plates

Driving plates as trapezoidal sheet plates as standard, options see "Extra Equipment".

Extra Equipment and Options



Driving plates

Alu-bulb-plate in the walking area even more user friendly when walking and driving.



Catwalks

Positioning on the left side of the parking space even more comfortable, when walking to the driver's door. 1,5mm zinc sheet, surface are coined. The catwalks are screwed to the driving plates, available with corrosion protection version "Classic" or "Classic Plus".

Dimensions: approx. 350cm x 31/41 cm (L x W)

Width of parking space

Width of parking space 240cm and 250cm is recommended for even more vehicle comfort.

Vehicle weight

Optional vehicle weight: up to 2600kg

Additional sound insulation

- structure-borne noise package to comply with DIN 4109 and adherence to sound insulation-measure R_w '57
- sound insulation hood to minimize airborne sound

Hydraulic

- HVLP 32-330 oil for high fluctuations in temperature

Installation of gates

- see detail on page 3 „Installation Layout Gates“

Protection against corrosion

Corrosion protection „Premium“ of driving plates by individual piece-galvanizing to DIN ISO 1461.

Corrosion protection „Premium Plus“ of driving plates individual piece-galvanizing to DIN ISO 1461 and coating of the top surfaces.

Modem for Teleservice/Online diagnosis

With the Nussbaum CAN-BUS control system (delivery includes modem) remote maintenance and tele-service are possibilities. This allows the Nussbaum parking experts a "tele-presence" at the customer in a matter of seconds for analysis and support. (on site: modem/DSL connection Euro-DSL SO).

Tips

- We recommend a maintenance contract.
- Attendance & cleaning according to recommendations or in regular intervals.

Interfaces to be performed by the Buyer

Foundation

Foundation works exactly to size, clean and dry is to be completed by the start of the installation. Bonded anchors for high foundation requirements shall be provided if necessary, available also as option.

Foundation plan

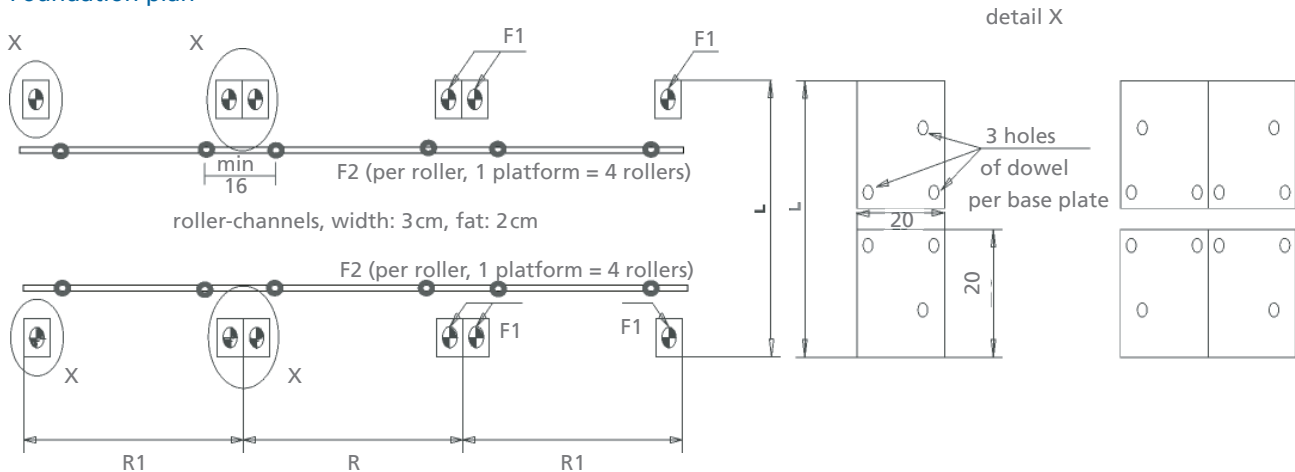

platform width	raster R	raster outer R1	length L	force F1	force F2	force F3
230	250	260	545*	14 kN	6 kN	10 kN
240	260	270	545*	14 kN	6 kN	10 kN
250	270	280	545*	14 kN	6 kN	10 kN

*540 available on request

All dimensions in cm.

Electrical data

- lockable main switch outside of installation, near to hydraulic unit, completed at the beginning of installation, height approx 180cm above entrance level (color requirements to EN 60204-1, 10.7.4, color red)
- capacity of the hydraulic unit: 400volt, 50hz, three-phase motor 3,0 kW
- supply line to switch cabinet 5 x 2,5mm², or to local requirements, fuse protection 3 x 16 amp, slow
- electrical potential equalisation (foundation grounding steel-construction to VDE 0100 T410)
- telephone line dto by modem and teleservice/ online analysis available on request
- free space for switch cabinet LWH approx. 60cm x 22cm x 80cm, with pivot door in direct near of system (max. 6m) with access to the parking system

General costumers duties

- level surface (H x W) 25cm x 26cm to attach the control panel, close to the system, outside the platform area
- safeguarding according to DIN EN 294
- lighting according to DIN 67528, illumination of parking lots and buildings for parking
- 10cm wide, yellow-black marking in front of each segment according to ISO 3864, insofar that no gates are installad
- compliance with installation requirements as per quotation
- foundation works exactly to size, clean and dry

Evenness tolerances

According to DIN EN 14010 the danger of trapping between nonparallel platform edges and the ground has to be prevented. The distance between the lower flange of the platforms and the garage ground must therefore not exceed 2cm. To adhere to the safety regulations and to get the necessary even ground, the tolerances of evenness to DIN 18202, table 3, line 3, must not be exceeded. Therefore exact levelling of the ground by the client is essential.

Abstract from DIN 18202, table 3

column	1	2	3	4	5	6
line	reference	Vertical measurements as limits in mm with measuring points distances in m to*				
		0,1	1	4	10	15
2	Unfinished to surface of covers, subconcrete and subsoils for higher demands, e.g. as foundation for cast plaster floor, industrial soils, paving tiles and slabstone paving, compound floor paving. Finished surfaces for minor purposes, e.g. warehouses, cellars.	5	8	12	15	20
3	Finished grounds, e.g. floor pavement serving as foundation for coverings. Coverings, tile coverings, PVC flooring and glued coverings.	2	4	10	12	15

* Intermediate values are to be taken out the diagram and must be rounded-off to mm.

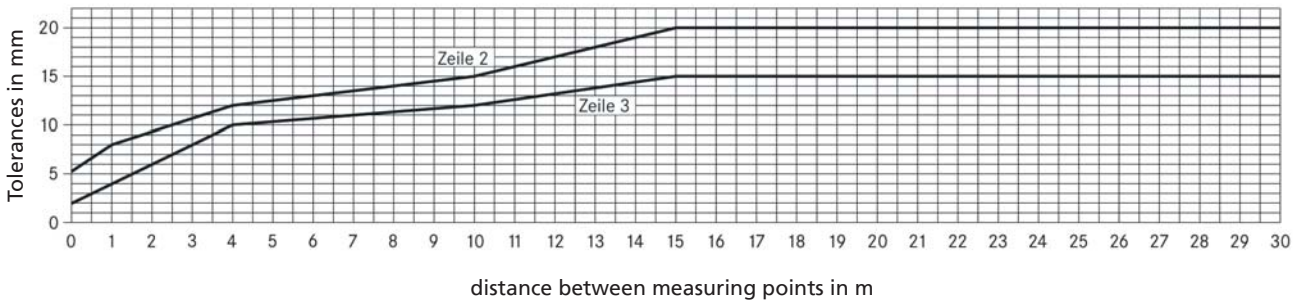

Electric Installation

Installation diagram, example with 2 segments for 3 parking spaces

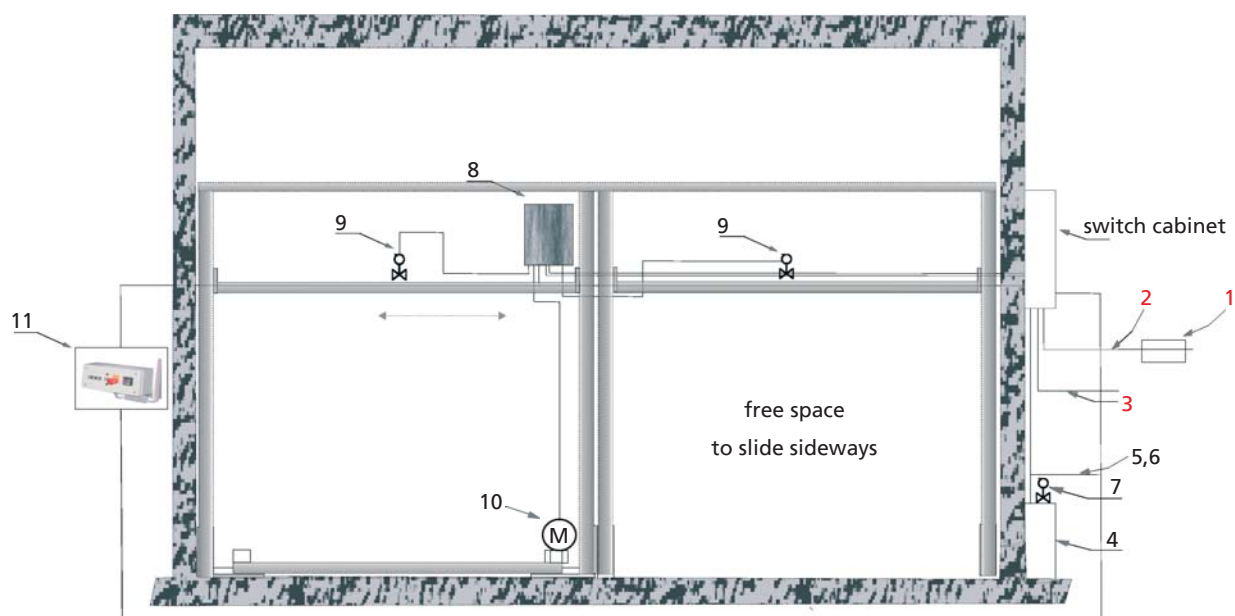

Item	Performance	Quantity	Designation	Location	Frequency
1	on site	1	fuse or automatic circuit 3 x 16 amp slow to DIN VDE 0100 part 430	in the feed cable	1x per system
2	on site	1	feed cable 5 G 2,5mm ² or to local requirements	in the feed cable to the switch cabinet	1x per system
3	on site	1	potential equalisation to DIN EN 60204	from foundation earth connector to the system	1x per system
4	Nussbaum	1	hydraulic unit with 3-phase motor 400volt, 50hz 3kW		
5	Nussbaum	1	supply line 5 G 2,5mm ² with marked wires and protective conductor	motor connector hydr. unit to switch cabinet	
6	Nussbaum	2	control line 2 x 1 ²		
7	Nussbaum	2	hydraulic valve		
8	Nussbaum	1	segment box		
9	Nussbaum	2	segment valve	moving platform	
10	Nussbaum	1	electrical motor		
11	Nussbaum	1	control element with emergency stop		

The items 4-11 are included in the scope of supply, unless otherwise specified in the offer/order.