

Quadro Outdoor T2 S/D

Our solution for high demands –
outdoor operation – no columns or
any other barrier in the area of the doors

Areas of application:

private houses, residential buildings, hotels, office buildings

For permanent use only!

Both platforms are horizontally accessible

Load per platform
max. 2000 kg
(wheel load
max. 500 kg)

Dimensions in cm.

pit depth	pit length	clearance	car-height below	car-height above
180	540	325	150	ab 155
200	540	345	170	ab 155
230	540	375	200	ab 155
260	540	405	230	ab 155

■ standard

Vehicle data

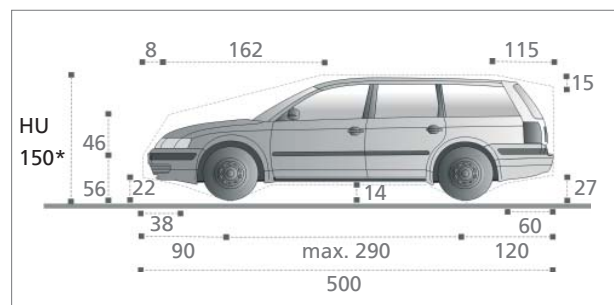
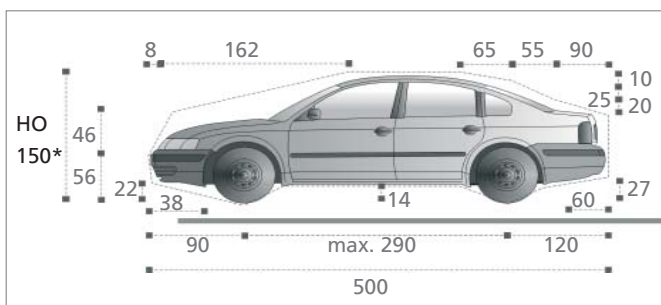

	standard	option
car-length (cm)	500	540
car-width (cm)	190	190
load per platform (kg)	max. 2000	max. 2600
load per wheel (kg)	max. 500	max. 625

Note

Car-height HO* and HU*: Alternative car-height, see table above.

The total car height including roof rail and antenna fixture must not exceed the mentioned max. height.

Width dimensions

All dimensions are minimum dimensions. All dimensions in cm. Tolerances to the German Norm VOB part C (DIN 18330, 18331) and DIN 18202 are to be considered.

Width dimensions

S = single installation for 2 cars

width of space	system width
230	260
240	270
250	280

D = double installation for 4 cars

width of space	system width
460	490
480	510
500	530

Note

1. With a pit depth of 260cm must be taken into consideration an additional width of + 5 cm (total width, see above + 5 cm).
2. Dimensions do not include the dimensions of the hydraulic unit. Dimensions of the hydraulic unit and the switch cabinet shown in page 4 below, are to be considered in the planning.

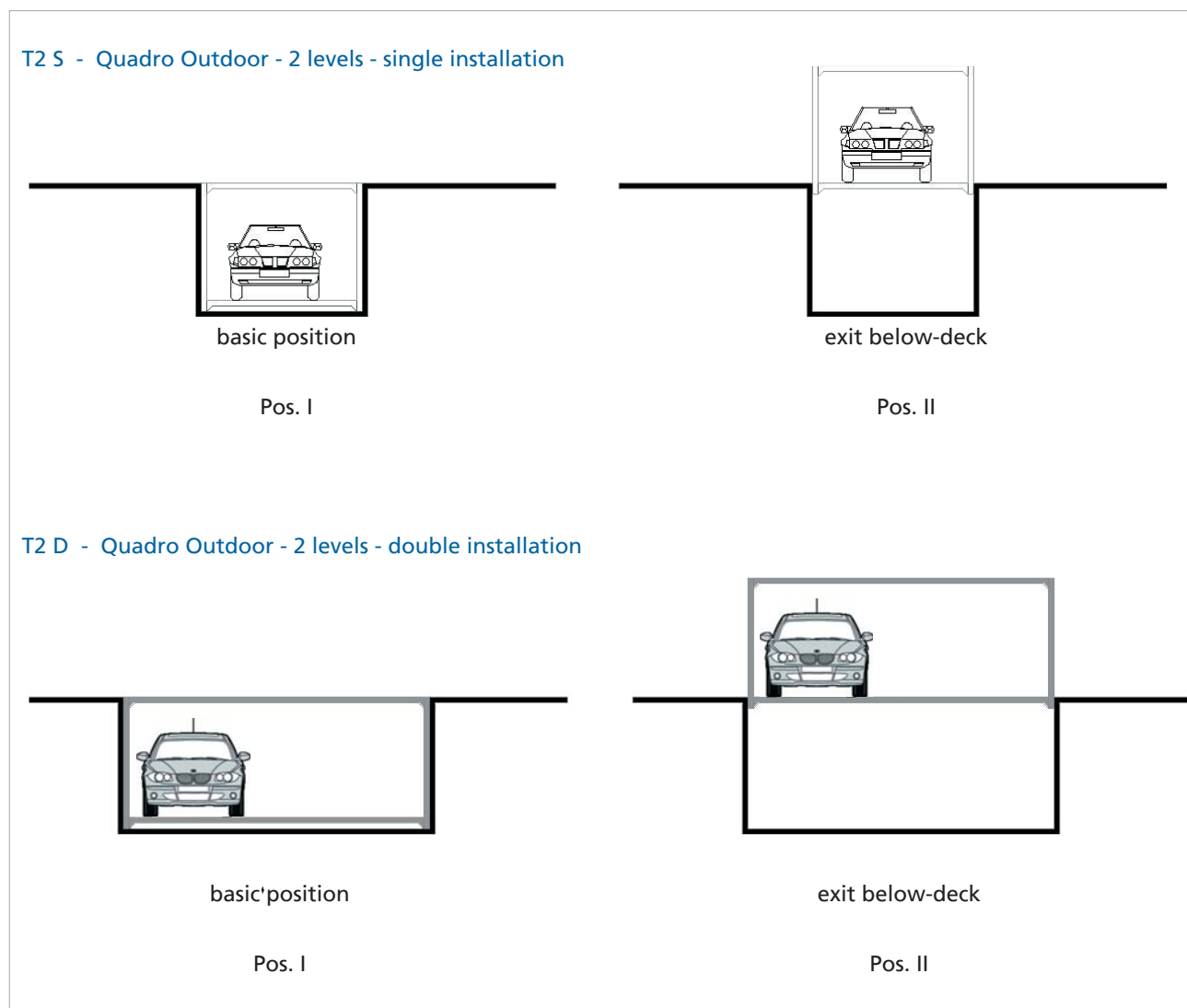

Features in the scope of delivery



- button lifting
- button lowering
- emergency stop
- key switch with key interlock

Outdoor operation terminal

Interlocked key switch, removal of the key only in the lower basic position.



Hydraulic unit

Hydraulic unit "Silencio" with tubing and wiring to the installation. The oil submerged motor "Silencio" is extremely quiet and smooth running. The motor-pump assembly is sound absorbent.

Positioning

- hydraulic unit placed directly on the lower platform, in the front left side, see picture above
- between or behind two systems in the pit on a 2m high support, see picture above

Dimensions incl. standard switch cabinet

- 115cm x 25cm x 75cm

Scope of supply

S/D-installation with 2 platforms, 4 telescope columns with hydraulic cylinder and hydraulic manifold

Width of parking space

Width of parking space 230cm and pit depth 200cm as standard

Safety devices

- 2 command-cycle-systems assembled over cross as synchronizing device for safe operation even with unequal load distribution on the platform
- entering wedge for easy drive-in and parking
- locking device prevents lowering by pipe breakage or leakage
- fixation of the car parking systems and hydraulic unit with HD-anchors, wiring and impact dowels
- railings to avoid risk of falling onto the platform, insofar as necessary

Note: Safety guards against shearing and squeezing have priority and must be provided by the Buyer.

Protection against corrosion

Corrosion protection version „Classic“ of driving plates by continuous line-galvanizing to DIN EN 10142/10143.

Corrosion protection version „Classic Plus“ of driving plates by line-galvanizing to DIN EN 10142/10143 (depending on the market specific needs zinc and powder coated sheet metal included in the scope of supply).



Driving plates

Driving plates as trapezoidal sheet plates as standard, options see "Extra Equipment".

Extra Equipment



Driving plates

Alu-bulb-plate in the walking area even more user friendly when going and cruise the system.



Catwalks

Positioning on the left side of the parking space even more comfortable, when walking to the driver's door. 1,5mm zinc sheet, surface area coined. The catwalks are screwed to the driving plates, available with corrosion protection version „Classic“ or „Classic Plus“. Dimensions approx. 350cm x 31/41 cm (L x W)



Platform coating

Tub for upper platform as a condition for a platform layer as for example planting vegetation, gravel, etc.

Width of parking space

Width of parking space 240 cm and 250 cm is recommended for even more vehicle comfort

Vehicle weight

Optional vehicle weight: up to 2600kg

Additional sound insulation

- structure-borne noise package to comply with DIN 4109 and adherence to sound insulation-measure R_w '57
- sound insulation hood to minimize airborne sound

Hydraulic

- HVLP 32-330 oil for high fluctuations in temperature

Protection against corrosion

- Corrosion protection version „Premium“ of driving plates by individual piece-galvanizing to DIN ISO 1461
- Corrosion protection version „Premium Plus“ of driving plates by individual piece-galvanizing to DIN ISO 1461 and coating of the top surfaces

Carport

A carport roofing which is fastened directly to the system can be delivered optionally. Details on request.

Tips

- We recommend a maintenance contract.
 - Attendance and cleaning according to recommendations or in regular intervals.
-

Interfaces to be performed by the Buyer

Foundation

Foundation works exactly to size, clean and dry is to be completed by the start of the installation. Bonded anchors for high foundation requirements shall be provided if necessary, available also as option.

Foundation plan

	S-installation	D-installation
F1	15 kN	27.5 kN
F4	+/- 1 kN	+/- 1 kN
F5	10 kN	10 kN

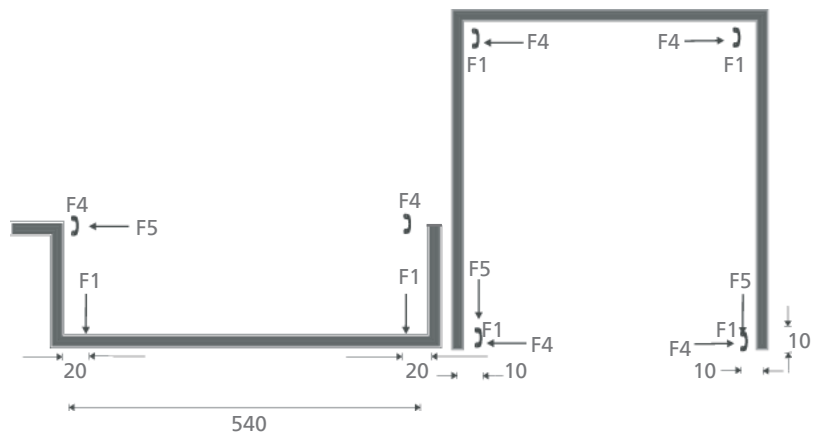

The pit must be executed in compliance with the designated forces. The forces and loads are transferred to the foundation by bearing plates with an area of 150cm². The bearing plates are fixed with metal expansion anchors. The drill hole depth is approx. 14 cm. All walls in the pit below the entrance level must be of concrete.

Electrical data

- supply line to main switch 5 x 4 mm² or according to local requirements, fuse protection 3 x 25 amp, slow
- lockable main switch, near to hydraulic unit but outside of the pit, completed at the beginning of installation, height approx. 180cm above entrance level (color requirements to EN 60204-1, 10.7.4, color red)
- hydraulic unit: 400V, 50 Hz, threephase motor 6,0 kW
- electrical potential equalisation (foundation grounding steel-construction to VDE 0100 T410)

General costumers duties

- level surface (L x W) 50cm x 20cm to attach the control panel, close to the system, outside the operational platform area
- safeguarding according to DIN EN 294
- lighting according to DIN 67528, illumination of parking lots and buildings for parking
- at the edge of the pit a 10cm wide, yellow-black marking according to ISO 3864
- wall opening 10cm x 10cm for hydraulic and electrical lines in case of intermediate walls
- platform above: snowy loads, according to local regulations, must be taken into consideration
- compliance with installation requirements as per quotation

lockable main switch



safeguarding to DIN EN 294



marking pit edge



Function

Function description,
figure to the right – Quadro Outdoor with 3 levels

The upper platform is the basic position on area standard, the installation in lowered position.

For driving on the lower platforms the system is put and raised by means of keyswitches and "dead man control " into operation. Depending on the system can want to drive on the middle or lower platform now.

Leadership wedges coordinated with the car take care that the car be stopped in the right position and damages are excluded.

By pressing the keyswitch "lower" the installation is taken to starting position again. The key can be removed only now.

Being allowe to not hold back themselves any persons during the operation in the installation.



Electrical data

Installation diagram

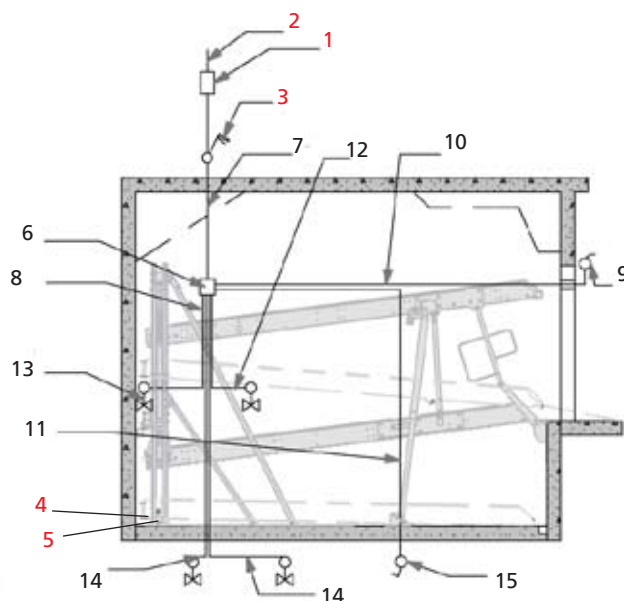

Figure: Car parking system with inclined accessible platforms. Specifications are also apply to systems with horizontal accessible platforms.

Item	Performance	Quantity	Designation	Positioning	Frequency
1	on site	1	fuse or automatic circuit 3 x 25 amp slow to DIN VDE 0100 part 430	in the feed cable	1x per hydr. unit
2	on site	1	supply line 5 G 4,0mm ² or according to local regulations	feed cable to main switch	1x per hydraulic unit
3	on site	1	lockable main switch	near hydraulic unit	1x per hydr. unit
4	on site	each 10 m	foundation earth connector	corner pit floor/ rear wall	
5	on site	1	potential equalisation to DIN EN 60204	from foundation earth connector to the system	1x per hydraulic unit
6	Nussbaum	1	hydraulic unit with three-phase motor 230/400volt, 50hz 6kW		
7	Nussbaum	1	supply line 5 G 4,0mm ² with marked wires and protective conductor	from main switch to hydraulic unit	1x per hydraulic unit
8	Nussbaum	1	control line 2x1		
9	Nussbaum	1	control element with emergency stop		
10	Nussbaum	1	control line 4G1		
11	Nussbaum	1	control line 4G1		
12	Nussbaum	1	control line 2x1		
13	Nussbaum	1	hydraulic valve lifting and lowering by installation in ranks		
14	Nussbaum	1	hydraulic valve lifting and lowering		
15	Nussbaum	1	control element for each further system		

The items 6 – 15 are included in the scope of supply, unless otherwise specified in the offer/order.